



Compressor
Voltage Code : FZ

CAJ9510Z-FZ

High Temp. Commercial (MHP)

220 - 240V 1~ 50 Hz

R452A / R404A / R448A / R449A

AJK510Z-FZ3B

Conditions	Frequency	Nominal Cooling Capacity		Sound Power ISO3745 / ISO 3743-1
		Watts	BTU/h	
EN12900 / R452A	50 Hz	2354	8027	63 dBA
EN12900 / R404A	50 Hz	2348	8007	63 dBA
EN12900 / R448A	50 Hz	2356	8034	63 dBA
EN12900 / R449A	50 Hz	2356	8034	63 dBA

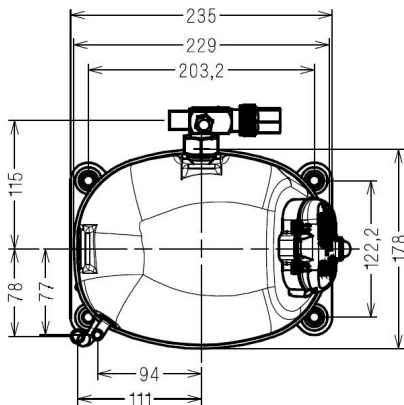
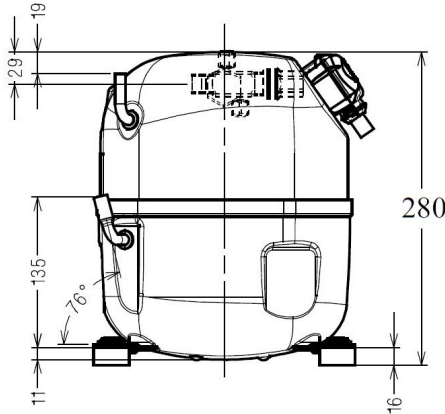

* EN12900 : T°Cond. 50.0°C / T°Evap. 5.0°C / T°Return gas temp.. 20.0°C
T°Subcooling. 0.0K

Certificates :



Displacement (cc)	18.3
Net Weight (Kg)	21.4
Oil Quantity (cc)	475.0
Oil Type	Polyolester
Expansion Device	Capillary_Tube/Expansion_Valve
Cooling	Fan
Main Winding (Ohm)	2.9
Start Winding (Ohm)	8.8
Current	
RLA (A)	5.4
MCC (A)	8.4
LRA (A)	30
Electrical Equipment	CSR
Overload	MRA38128
Time Check	2.8s - 5.2s / 20.5 A
Open Temp	105° C
Close Temp	52° C
Optional	/
Start Capacitor	100 µF / 330 V
Run Capacitor	15 µF / 400 V
Potential Relay	RVA40**
Pick Up	280/310V
Drop Out	60/121V
Optional	3ARR3*6AC*
Refrigerating connection for OD	
Suction Tube	15.9 (5/8")
Discharge Tube	7.9 (5/16")
Process Tube	6.35 (1/4")

Note : Tecumseh reserves the right to change information contained in this document without notification.



Tecumseh

CAJ9510Z-FZ	Tension FZ : 220 - 240V 1~ 50 Hz
--------------------	---

Les performances sont données dans les **conditions EN12900** :
 Condition Dew
 The performance data are in **EN12900 conditions** :
 Dew Condition

Gaz aspirés : 20.0 °C
 Sous refroidissement : 0.0 K
 Return gas : 20.0 °C
 Subcooling : 0.0 K

50 Hz R452A											
											N°2430
4 T condensation	5 T évaporation	(°C)	-25	-20	-15	-10	-5	0	5	10	15
30	1 P frigorifique	(Watt)	904	1170	1489	1867	2313	2834	3438	4132	4925
	2 P absorbée	(W)	550	608	663	714	760	800	833	859	878
	3 I absorbée	(A)	2.69	2.94	3.18	3.40	3.61	3.80	3.99	4.15	4.31
40	1 P frigorifique	(Watt)	722	962	1241	1567	1947	2390	2902	3492	4167
	2 P absorbée	(W)	564	638	709	777	841	901	955	1003	1044
	3 I absorbée	(A)	2.67	3.01	3.34	3.65	3.95	4.23	4.51	4.77	5.02
50	1 P frigorifique	(Watt)		745	984	1257	1571	1934	2354	2838	3395
	2 P absorbée	(W)		651	740	826	910	990	1066	1137	1202
	3 I absorbée	(A)		3.04	3.45	3.86	4.25	4.63	4.99	5.35	5.69
60	1 P frigorifique	(Watt)			720	938	1185	1468	1794	2172	2609
	2 P absorbée	(W)			756	862	966	1068	1167	1261	1351
	3 I absorbée	(A)			3.53	4.02	4.51	4.98	5.44	5.89	6.33

50 Hz R404A											
											N°224ET-FZ
4 T condensation	5 T évaporation	(°C)	-25	-20	-15	-10	-5	0	5	10	15
30	1 P frigorifique	(Watt)	964	1234	1555	1935	2380	2898	3496	4182	4962
	2 P absorbée	(W)	583	642	698	748	793	832	864	888	903
	3 I absorbée	(A)	2.85	3.10	3.34	3.56	3.77	3.96	4.13	4.29	4.43
40	1 P frigorifique	(Watt)	771	1013	1292	1616	1991	2426	2927	3501	4156
	2 P absorbée	(W)	601	676	748	816	879	937	989	1035	1072
	3 I absorbée	(A)	2.85	3.19	3.52	3.83	4.13	4.41	4.67	4.92	5.15
50	1 P frigorifique	(Watt)		785	1022	1289	1594	1945	2348	2811	3340
	2 P absorbée	(W)		695	784	870	953	1031	1104	1172	1232
	3 I absorbée	(A)		3.24	3.66	4.06	4.45	4.82	5.17	5.51	5.83
60	1 P frigorifique	(Watt)			746	957	1191	1457	1762	2112	2516
	2 P absorbée	(W)			807	912	1015	1114	1209	1299	1384
	3 I absorbée	(A)			3.77	4.26	4.73	5.19	5.64	6.07	6.48



1 = cooling capacity 2 = power input 3 = current 4 = condensing temperature 5 = evaporating temperature

Nota : Tecumseh se réserve le droit de modifier les informations contenues dans ce document sans préavis.
Note : Tecumseh reserves the right to change information contained in this document without notification.

© 2018 Tecumseh Products Company
All rights reserved



Tecumseh

CAJ9510Z-FZ	Tension FZ : 220 - 240V 1~ 50 Hz
--------------------	---

Les performances sont données dans les conditions EN12900 :	Gaz aspirés :	20.0 °C
Condition Dew	Sous refroidissement :	0.0 K
The performance data are in EN12900 conditions :	Return gas :	20.0 °C
Dew Condition	Subcooling :	0.0 K

© 2018 Tecumseh Products Company
All rights reserved

50 Hz R448A (*)

N°2894

4 T condensation	5 T évaporation	(°C)	-25	-20	-15	-10	-5	0	5	10	15
30	1 P frigorifique	(Watt)	796	1057	1369	1742	2184	2704	3311	4012	4818
	2 P absorbée	(W)	513	566	618	667	712	751	784	809	825
	3 I absorbée	(A)	2.51	2.74	2.96	3.17	3.38	3.57	3.75	3.91	4.06
40	1 P frigorifique	(Watt)		873	1150	1476	1860	2310	2834	3442	4143
	2 P absorbée	(W)		598	665	730	791	849	901	946	984
	3 I absorbée	(A)		2.83	3.13	3.43	3.71	3.99	4.25	4.50	4.73
50	1 P frigorifique	(Watt)			927	1207	1532	1913	2356	2871	3467
	2 P absorbée	(W)			699	782	863	941	1015	1084	1145
	3 I absorbée	(A)			3.26	3.65	4.03	4.40	4.75	5.10	5.42
60	1 P frigorifique	(Watt)				940	1208	1520	1882	2305	2797
	2 P absorbée	(W)				820	924	1025	1123	1217	1306
	3 I absorbée	(A)				3.83	4.31	4.78	5.24	5.68	6.11

50 Hz R449A (*)

N°2410

4 T condensation	5 T évaporation	(°C)	-25	-20	-15	-10	-5	0	5	10	15
30	1 P frigorifique	(Watt)	796	1057	1369	1742	2184	2704	3311	4012	4818
	2 P absorbée	(W)	513	566	618	667	712	751	784	809	825
	3 I absorbée	(A)	2.51	2.74	2.96	3.17	3.38	3.57	3.75	3.91	4.06
40	1 P frigorifique	(Watt)		873	1150	1476	1860	2310	2834	3442	4143
	2 P absorbée	(W)		598	665	730	791	849	901	946	984
	3 I absorbée	(A)		2.83	3.13	3.43	3.71	3.99	4.25	4.50	4.73
50	1 P frigorifique	(Watt)			927	1207	1532	1913	2356	2871	3467
	2 P absorbée	(W)			699	782	863	941	1015	1084	1145
	3 I absorbée	(A)			3.26	3.65	4.03	4.40	4.75	5.10	5.42
60	1 P frigorifique	(Watt)				940	1208	1520	1882	2305	2797
	2 P absorbée	(W)				820	924	1025	1123	1217	1306
	3 I absorbée	(A)				3.83	4.31	4.78	5.24	5.68	6.11

1 = cooling capacity 2 = power input 3 = current 4 = condensing temperature 5 = evaporating temperature

(*) Veuillez vous référer strictement aux Recommandations d'Utilisation et Bulletins Marketing Tecumseh du fait de la température de reflux élevée pour les applications LBP.

(*) Due to very high discharge temperature especially on LBP conditions, please strictly refer to Tecumseh Guidelines & Marketing Bulletin when using this refrigerant.

Nota : Tecumseh se réserve le droit de modifier les informations contenues dans ce document sans préavis.

Note : Tecumseh reserves the right to change information contained in this document without notification.